

Pipe joint assemblies and fittings for  
high-density polyethylene (PE-HD) pressure pipes  
Adaptors for fusion jointing, flanges and sealing elements  
Dimensions

**DIN**  
**16 963**  
Part 4

Rohrverbindungen und Rohrleitungsteile für Druckrohrleitungen aus Polyethylen hoher Dichte (PE-HD);  
Bunde für Heizelement-Stumpfschweißung, Flansche, Dichtungen; Maße

*In keeping with current practice in standards published by the International Organization for Standardization (ISO),  
a comma has been used throughout as the decimal marker.*

Dimensions in mm

### 1 Field of application

This standard specifies dimensions of adaptors for fusion jointing using heated tools, of flanges and sealing elements used to interconnect high-density polyethylene (PE-HD) pressure pipes as specified in DIN 8074 and to connect such pipes to pipes and fittings made from materials other than PE-HD. The adaptors and flanged joints shall comply with the requirements specified in DIN 16 963 Part 5 (at present at the stage of draft).

For technical reasons, adaptors shall only be welded to pipes conforming to DIN 8074 or to pipe components of the same pipe series, the use of other components being permitted if their wall thickness in the weld area is equal to that of the pipes.

### 2 Dimensions, designation

Adaptors, flanges and sealing elements are not expected to conform to the designs illustrated here; compliance is only required in the case of the dimensions specified.

For dimensions without tolerance indication, the general tolerances given in DIN 7168 Part 1 or DIN 16 901 shall apply, at the manufacturer's discretion.

Continued on pages 2 to 8

No part of this standard may be reproduced without the prior permission of DIN Deutsches Institut für Normung e.V., Berlin.  
In case of doubt, the German-language original should be consulted as the authoritative text.

**Short adaptor**  
(item No.1)

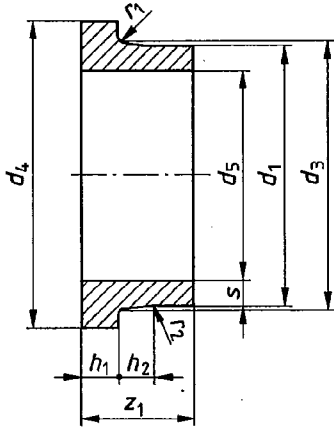

**Short adaptor**  
(item No.23)

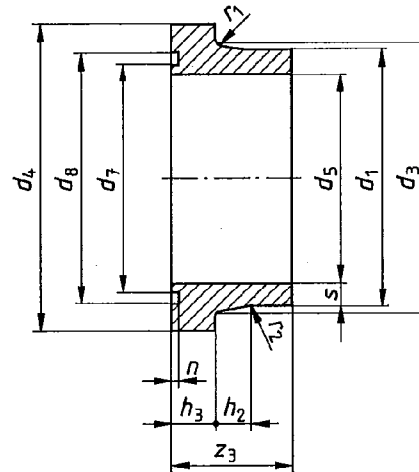

**Long adaptor**  
(item No.3)

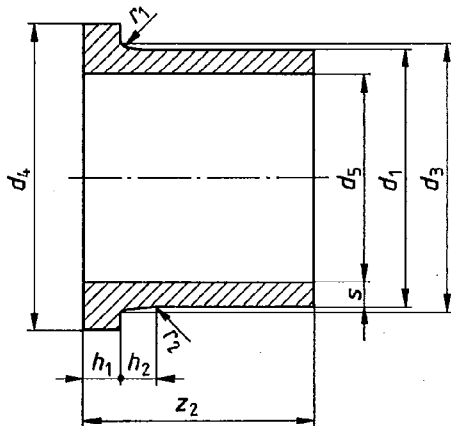

**Long adaptor**  
(item No.24)

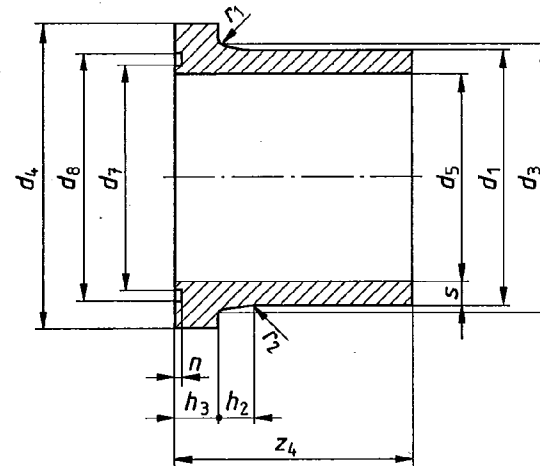

Example of a series 5 PE-HD adaptor (item No. 3) designed for a pipe outside diameter of 200 mm:

Adaptor DIN 16963 – 3 – 200 – 5 – PE-HD

Table 1. Adaptors (item Nos. 1, 3, 23 and 24)

Pipe out-side diameter, $d_1$	$d_3$	$d_4$	$d_5$ 1)					$d_6$	$d_7$	$d_8$	$r_1$	$h_1$ Pipe series					$h_2$ Pipe series					$r_2$ min.	$z_1$ min.	$z_2$ min.	$z_3$ min.	$z_4$ min.
			2 PN 3,2 Limit deviations	3 PN 4 Limit deviations	4 PN 6 Limit deviations	5 PN 10 Limit deviations	2					3	4	5	2	3	4	5	2	3	4					
20	27	45	-	-	16	+0,4	15	+1,2	29,7	20,9	20,9	-	-	7	13	-	10	-	3	20	50	85	53	88		
25	33	58	-	-	21	+0,4	19	+0,4	34,5	25,7	25,7	-	-	9	13	-	12	-	3	20	50	85	53	88		
32	40	68	-	-	27	+0,4	25	+0,4	42,4	33,6	33,6	-	-	10	13	-	13	-	4	20	50	85	53	88		
40	50	78	-	36	+0,4	34	+1,4	31	+1,6	53,7	40,1	40,1	11	11	15	-	16	16	3	20	50	85	53	88		
50	61	88	46	45	+0,4	43	+0,2	39	+0,8	63,2	49,6	49,6	12	12	15	-	17	17	3	20	50	85	53	88		
63	75	102	58	57	+1	55	+0,8	50	+1,4	78,9	65,3	65,3	14	14	20	19	19	4	20	50	85	53	88			
75	89	122	69	68	+1,2	65	+1,4	59	+2,2	91,6	78,0	78,0	16	16	20	21	21	4	20	50	85	53	88			
90	105	138	83	82	+0,4	78	+0,8	71	+2,6	110,5	96,9	96,9	17	17	20	22	22	4	20	80	140	85	145			
110	125	158	102	100	+1,4	96	+1,4	88	+3,8	132,8	114,8	114,8	18	18	25	24	24	4	20	80	140	85	145			
125	132	158	116	114	+1,2	109	+1,8	99	+3,2	132,8	114,8	114,8	18	18	28	24	24	4	20	80	140	85	145			
140	155	188	130	128	+0,2	122	+2,2	111	+3,4	160,2	146,2	146,2	18	18	28	24	24	4	20	80	140	85	145			
160	175	212	149	146	+1,6	139	+2,8	127	+3,8	189,6	171,6	171,6	18	18	28	24	24	4	20	80	140	85	145			
180	180	212	167	164	+1,8	157	+2,6	143	+4,8	178,4	160,2	160,2	18	18	30	24	24	4	20	80	140	85	145			
200	232	268	186	183	+1,6	174	+3,2	159	+4,6	210,2	192	192	18	18	30	24	24	4	20	100	200	106	206			
225	235	268	209	205	+2,9	196	+2,9	179	+5,9	216	197,8	197,8	18	18	30	24	24	4	20	100	200	106	206			
250	285	320	232	228	+0	218	+0	199	+0	-	-	-	20	20	40	-	-	4	20	100	-	-	-			
280	291	320	260	256	+0,1	245	+0,1	223	+0,1	-	-	-	20	20	35	-	-	4	20	100	-	-	-			
315	335	370	293	288	+0,3	275	+0,3	251	+0,3	-	-	-	20	20	35	-	-	4	20	100	-	-	-			
355	373	430	330	324	+0	310	+0	283	+0	-	-	-	23	23	40	-	-	6	20	120	-	-	-			
400	427	482	372	366	+0,6	350	+0,6	319	+0,6	-	-	-	26	26	45	-	-	6	20	120	-	-	-			
450	514	585	419	411	+0,8	393	+0,8	359	+0,8	-	-	-	33	33	60	-	-	6	20	120 <sup>2)</sup>	-	-	-			
500	530	585	465	457	+0	437	+0	399	+0	-	-	-	33	33	60	-	-	6	20	120	-	-	-			
560	615	685	521	512	+0,2	490	+0,2	447	+0,2	-	-	-	35	35	60	-	-	6	20	120 <sup>2)</sup>	-	-	-			
630	642	685	586	576	+0,5	551	+0,5	503	+0,5	-	-	-	35	35	60	-	-	6	20	120	-	-	-			
710	737	800	661	649	+0	621	+0	448	+0	-	-	-	35	35	60	-	-	8	20	120	-	-	-			
800	840	905	745	732	+0	700	+0	498	+0	-	-	-	36	36	60	-	-	8	20	120	-	-	-			
900	944	1005	838	823	+0	787	+0	568	+0	-	-	-	40	40	60	-	-	8	20	120	-	-	-			
1000	1047	1110	931	915	+0	875	+0	645	+0	-	-	-	42	42	60	-	-	8	20	120	-	-	-			
1200	1245	1330	1117	1098	+0	1098	+0	817	+0	-	-	-	50	50	60	-	-	8	20	140	-	-	-			

1) From  $d_1 = 225$  mm, the specified values of  $d_5$  allow for the tapering of the pipe.

2) For pipe series 5,  $z_1 = 130$  mm.

Flange (item No.2)

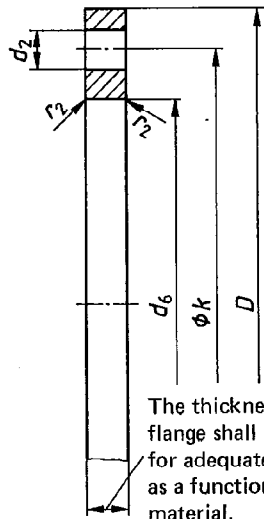

The thickness of the flange shall be designed for adequate strength, as a function of the material.

Designation of a glass fibre reinforced plastics<sup>5)</sup> flange (item No.2) for a pipe outside diameter of 75 mm and rated for PN 10:

Flange DIN 16963-2-75-10 GFK

Table 2. Flanges (item No. 2)

Nominal flange size DN	Pipe outside diameter, $d_1$	$D^4)$	$d_2^4)$	$d_6^3)$	$k^4)$	Bolts		$r_2$
						Number	Thread size	
15	20	95		28	65	4	M12	3
20	25	105	14	34	75			
25	32	115		42	85			
32	40	140		51	100	4	M16	3
40	50	150	18	62	110			
50	63	165		78	125			
65	75	185		92	145	4	M16	3
80	90	200	18	108	160			
100	110	220		128	180			
100	125	220	18	135	180	8	M16 M16 M20	3
125	140	250	18	158	210			
150	160	285	22	178	240			
150	180	285		188	240	8	M20	3
200	200	340	22	235	295			
200	225	340		238	295			
250	250	395		288	350	12	M20	3
250	280	395	22	294	350			
300	315	445		338	400			
350	355	505	22	376	460	16	M20	4
400	400	565	26	430	515			
500	450	670	26	517	620			
500	500	670	26	533	620	20	M24	4
600	560	780	30	618	725			
600	630	780	30	645	725			
700	710	895	30	740	840	24	M27	5
800	800	1015	33	843	950			
900	900	1115	33	947	1050			
1000	1000	1230	36	1050	1160	28	M30	5
1200	1200	1465	39	1260	1380			
3) From $d_1 = 63$ mm, identical with the values given in DIN 2673, except for $d_1 = 450$ mm and 560 mm, where $d_6$ values are identical with those given in DIN 2642. 4) See DIN 2501 Part 1 for flange connecting dimensions.								

5) See table 5 for flange materials and for material symbols to be used in the designation.

Gasket (item No.7) 6)

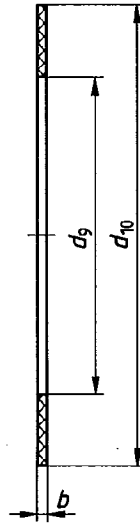

Designation of a pipe series 3 gasket (item No.7) designed for a pipe outside diameter of 250 mm:

Gasket DIN 16963-7-250-3

6) Other suitable cross-sectional dimensions shall be permitted.

Table 3. Gaskets (item No.7)

Pipe outside diameter, $d_1$	$d_{10}$	$d_9$ Pipe series				$b$
		2	3	4	5	
20	45	—	—	—	16	2
25	58	—	—	21	20	
32	68	—	—	28	26	
40	78	—	36	35	33	2
50	88	—	46	44	41	
63	102	59	58	56	51	
75	122	70	69	66	61	2
90	138	84	83	80	74	2
110	158	103	101	97	90	3
125	158	117	115	111	102	3
140	188	131	129	124	114	
160	212	150	148	142	131	
180	212	169	166	160	147	3
200	268	188	185	177	164	
225	268	211	208	199	184	
250	320	234	231	222	204	3
280	320	263	258	248	229	
315	370	295	291	279	258	
355	430	333	328	315	290	3
400	482	375	369	355	327	
450	585	422	415	399	368	
500	585	469	461	443	409	3
560	685	525	517	497	456	
630	685	591	581	559	513	
710	800	666	655	630	—	3
800	905	750	738	709	—	
900	1005	844	831	798	—	
1000	1110	938	923	885	—	
1200	1330	1126	1108	—	—	

## O ring (item No.8)

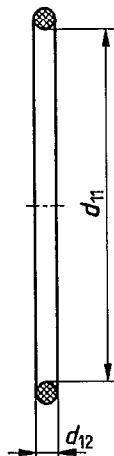

Table 4. O rings (item No.8)

Pipe outside diameter, $d_1$	$d_{11}$		$d_{12}$		Identical with (standard designation of O ring)
		Limit deviations		Limit deviations	
20	23,4				DIN 8063 - 16 - 20
25	28,2	$\pm 0,4$	3,5	$\pm 0,1$	DIN 8063 - 13 - 25
32	36,1				DIN 8063 - 16 - 32
40	43,8	$\pm 0,5$			DIN 8063 - 16 - 40
50	53,3	$\pm 0,5$	5,3	$\pm 0,13$	DIN 8063 - 16 - 50
63	69,2	$\pm 0,7$			DIN 8063 - 16 - 63
75	81,9		5,3	$\pm 0,13$	DIN 8063 - 16 - 75
90	101	$\pm 0,7$	5,3	$\pm 0,13$	DIN 8063 - 16 - 90
110	120		7	$\pm 0,15$	DIN 8063 - 16 - 110
125	120	$\pm 0,7$			DIN 8063 - 16 - 110
140	151,8	$\pm 1,2$	7	$\pm 0,15$	DIN 8063 - 16 - 140
160	177,2	$\pm 1,2$			DIN 8063 - 16 - 160
180	164,4				DIN 16963 - 8 - 180
200	196,2	$\pm 1,2$	7	$\pm 0,15$	DIN 16963 - 8 - 200
225	202,5				DIN 16963 - 8 - 225

## 3 Materials

Table 5. Materials

Name of component	Item No.	Permitted material							PE-HD
		GG	St	Al	PP-GF	PVC	GFK		
Short adaptor	1								X
Short adaptor	23								X
Long adaptor	3								X
Long adaptor	24								X
Flange	2	X	X	X	X	X	X		
Gasket	7	Materials subject to agreement.							
O ring	8								
<p>The materials suitable for the components listed are marked X.</p> <p>GG = cast iron (grey cast iron) as specified in DIN 1691</p> <p>St = USt 37-2 or RSt 37-2 as specified in DIN 17 100, at the manufacturer's discretion</p> <p>Al = light alloy</p> <p>PP-GF = glass fibre reinforced polypropylene</p> <p>PVC = PVC-U as specified in DIN 8063 Part 5</p> <p>GFK = glass fibre reinforced plastics</p> <p>PE-HD = high-density polyethylene as specified in DIN 16963 Part 5 (cf. Explanatory notes)</p> <p>For item Nos. 7 and 8, the material shall be agreed as a function of the type, concentration and service temperature of the medium conveyed.</p>									

**4 Assemblies**

Adaptors, flanges and sealing elements as specified in clause 2 may be used to make the flanged joints shown below.

**Type F1 flanged joint** (for sizes from DN 15 to DN 1200)    **Type F6 flanged joint** (for sizes from DN 15 to DN 200)

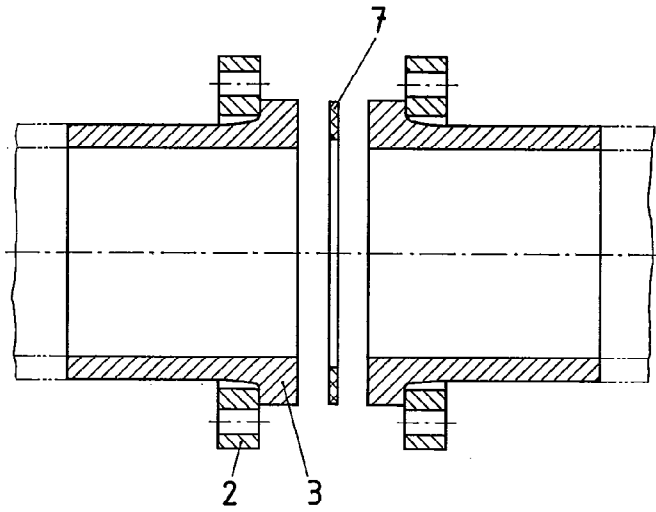
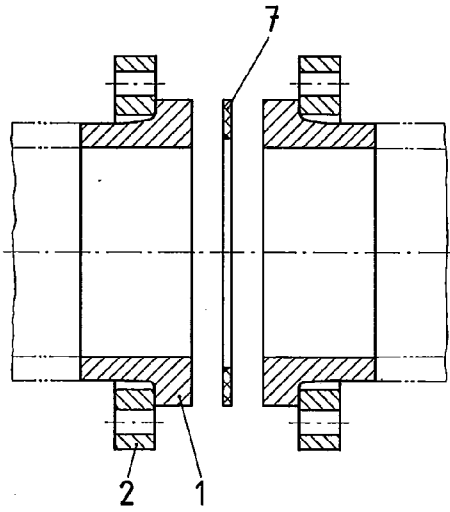

**A**

Item No.	Name of component
1	Short adaptor
2	Flange
7	Gasket

**B**

Item No.	Name of component
2	Flange
3	Long adaptor
7	Gasket

**Type F2 flanged joint** (for sizes from DN 15 to DN 1200)

**Type F7 flanged joint** (for sizes from DN 15 to DN 200)

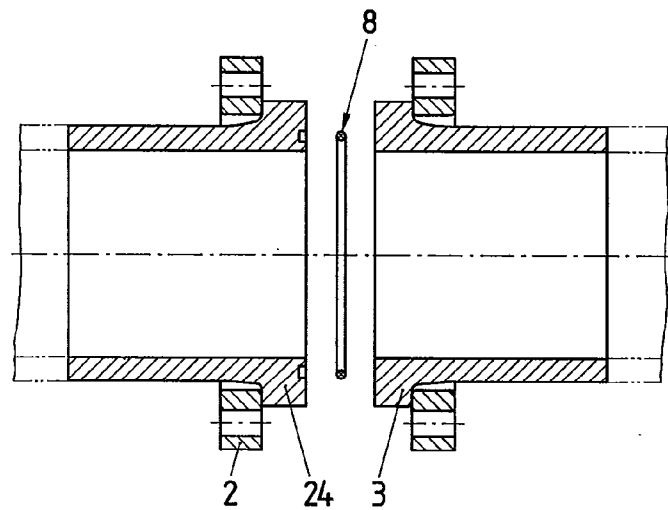
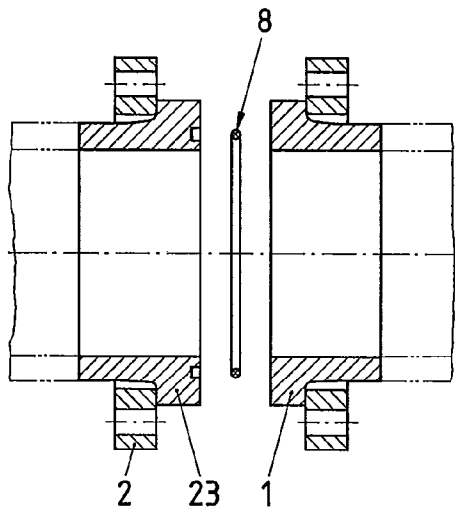

**C**

Item No.	Name of component
1	Short adaptor
2	Flange
8	O ring
23	Short adaptor

**D**

Item No.	Name of component
2	Flange
3	Long adaptor
8	O ring
24	Long adaptor

**Standards referred to**

DIN 1691	Flake graphite cast iron (grey cast iron); properties
DIN 2501 Part 1	Flanges; connecting dimensions
DIN 2642	Loose flanges with collar and plain collars, rated for PN 10
DIN 2673	Loose flanges and adaptors rated for PN 10
DIN 7168 Part 1	General tolerances; linear and angular dimensions
DIN 8063 Part 3	Pipe joint assemblies and fittings for unplasticized polyvinyl chloride (PVC) pressure pipes; pipe couplings; dimensions
DIN 8063 Part 4	Pipe joint assemblies and fittings for unplasticized polyvinyl chloride (PVC-U) pressure pipes; bushings, flanges and sealing elements; dimensions
DIN 8063 Part 5	(at present at the stage of draft) Pipe joint assemblies and fittings for unplasticized polyvinyl chloride (PVC-U) pressure pipes; general quality requirements and testing
DIN 8074	High-density polyethylene (PE-HD) pipes; dimensions
DIN 16901	Plastics mouldings; tolerances and acceptance conditions for linear dimensions
DIN 16963 Part 5	(at present at the stage of draft) Pipe joint assemblies and fittings for high-density polyethylene pressure pipes; general quality requirements and testing
DIN 17 100	Steels for general structural purposes; quality standard

**Explanatory notes**

This standard has been prepared by Subcommittee 504.4 *Kunststoff-Fittings für Rohre aus Thermoplasten* of the *Normenausschuß Kunststoffe* (Plastics Standards Committee).

The adaptor dimensions have been specified on the assumption that the adaptors are made from a moulding compound showing the same characteristics in the long-term hydrostatic pressure test as the type 1 PE-HD pipes specified in DIN 8075 Part 1, August 1976 edition (withdrawn).

**International Patent Classification**

B 29 C 65/18  
B 29 C 65/20  
B 29 C 67/14  
F 16 L 47/00